

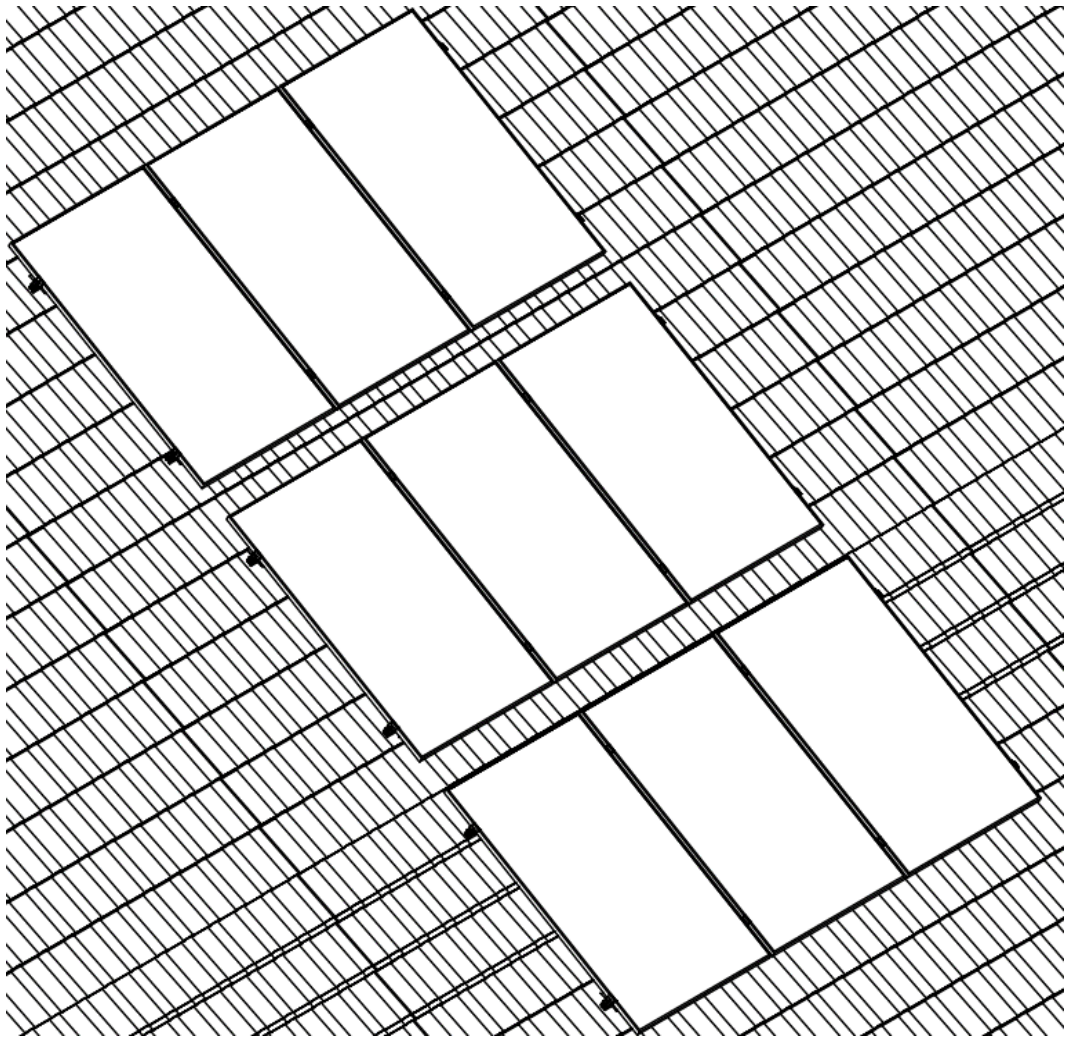

# INSTALLATION MANUAL FOR ROOF CERAMIC TILE MOUNTING SYSTEM



**The mounting system described below is used to mount photovoltaic modules on pitched roof.**

During production every effort was made to provide you with a product of the highest quality which is also easy to mount. This instruction is a set of rules for the correct mounting of the mounting structure components, but is not a blueprint or a substitute for it. The installer performing the mounting must be properly trained and licensed for the job. Overall responsibility for proper mounting rests with the installer who should select the appropriate type of construction.

In situations where the strength of the roof structure is questionable, a structural engineer should be consulted to perform strength calculations for the roof.

1. The layout of the modules shall be arranged to minimize or preclude the appearance of shadow on the modules. Keep in mind that even the shadow cast by trees or buildings can limit the yields generated by modules. When mounting the system in summer, be aware that the shadow cast by trees and neighboring buildings will reach much further in winter. Also remember to keep the safe zone on the roof sheathing - figure 1

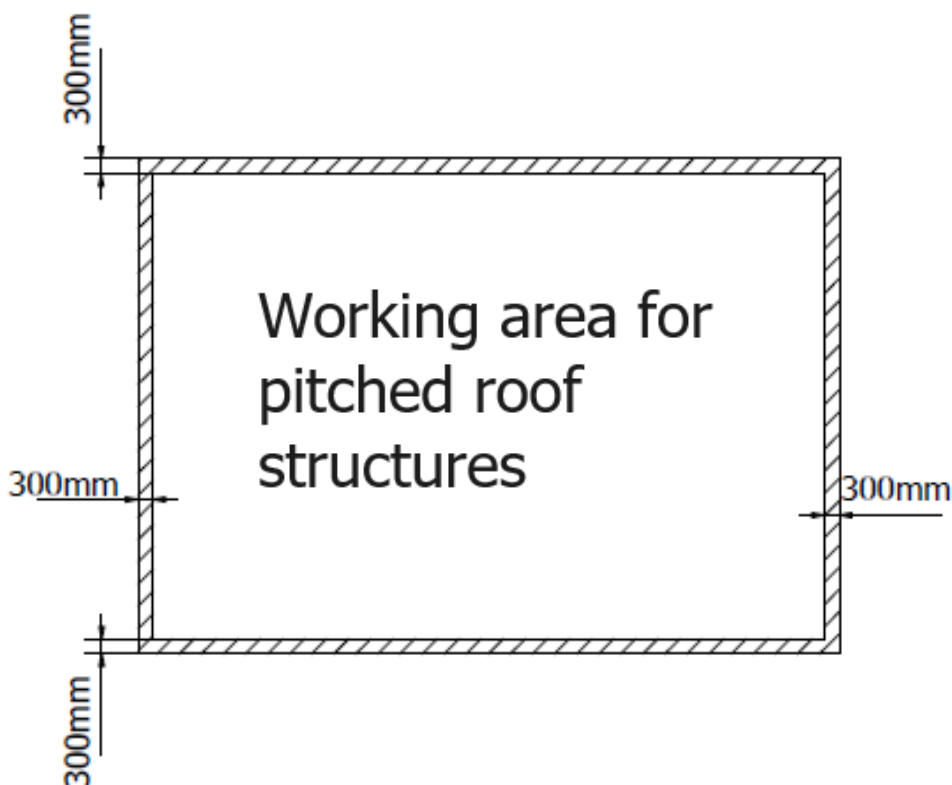

FIGURE. 1 Working area for pitched roof structures

2. The length of one row of modules can be calculated using the two formulas described below.
- a. Formula for row mounted on short side:

$$\text{ROW LENGTH} = \text{NUMBER OF MODULES IN THE ROW} * \text{MODULE} + 20\text{mm} + 60\text{mm}$$

$$\text{ROW LENGTH} = (\text{MODULE LENGTH} + 20) * \text{NUMBER OF MODULES} + 60$$

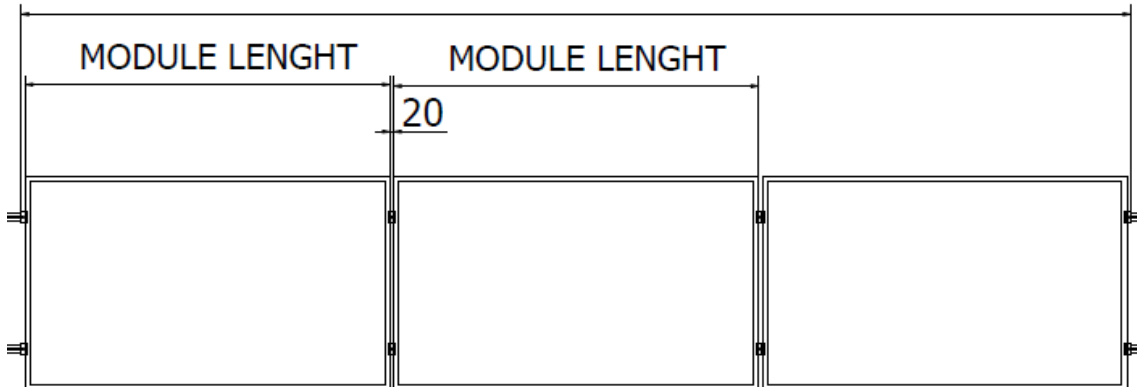

FIGURE. 2 Construction row length for short side mounted modules.

- b. Formula for a row mounted on the long side:

$$\text{ROW LENGTH} = \text{NUMBER OF MODULES IN THE ROW} * \text{MODULE} + 20\text{mm} + 60\text{mm}$$

$$\text{ROW LENGTH} = (\text{MODULE WIDTH} + 20) * \text{NUMBER OF MODULES} + 60$$

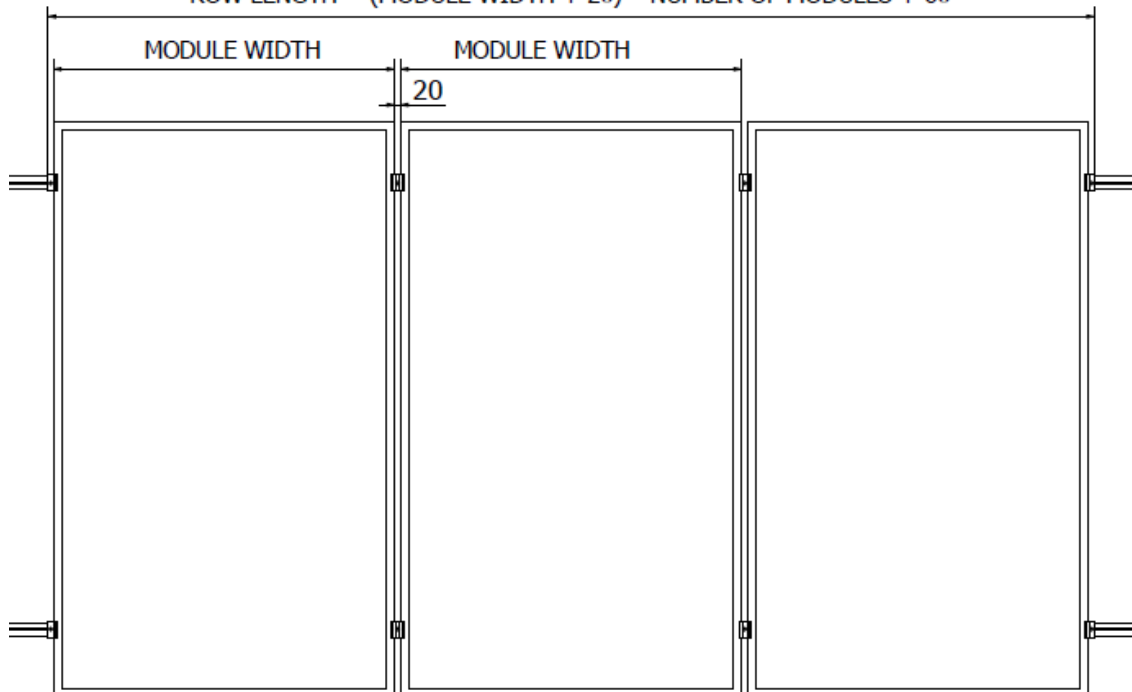

FIGURE. 3 Length of the row of structures mounted on the long side

3. The spacing between each mounting point depends on the mounting profile selected and how the module is mounted to the bracket. The maximum between brackets is recorded in Table 1 and Table 2.
- a. For long side mounting

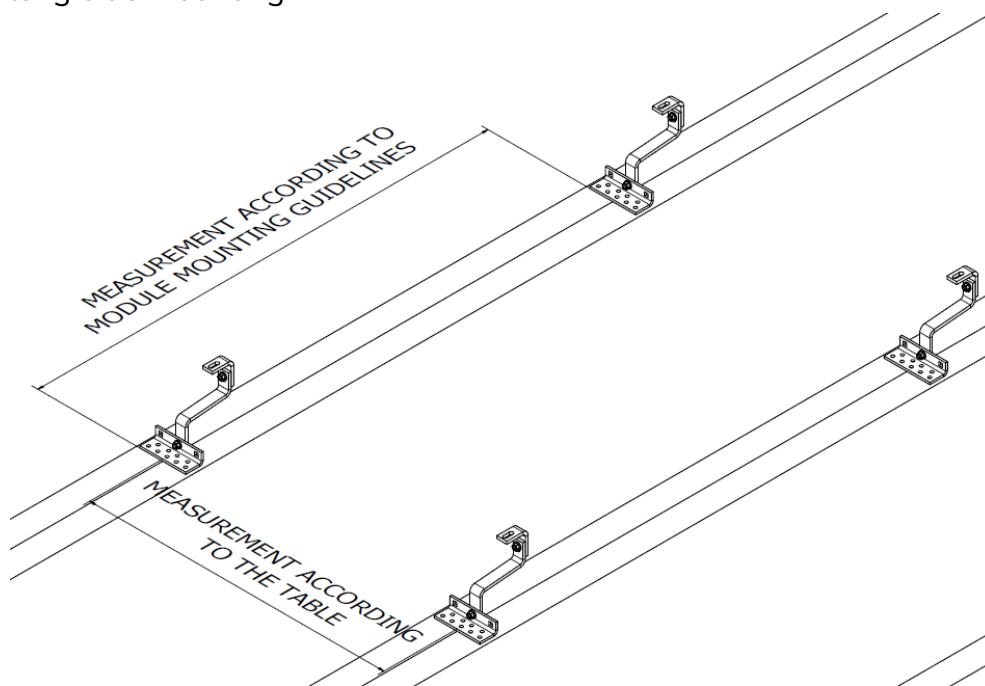

FIGURE. 4 Bracket spacing

Tab.1 Maximum spacing of brackets

Module length	K-01	K-25
1780mm	1,2 [m]	1,2 [m]
2275mm	1,1 [m]	1,1 [m]

b. For mounting on the short side

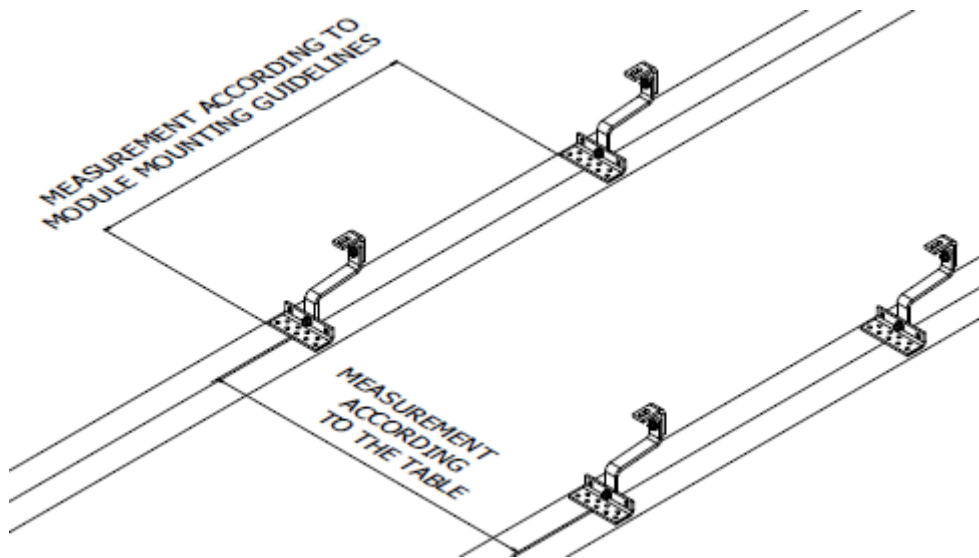

FIGURE. 5 Bracket spacing

Table 2 Maximum spacing of brackets

Module length	K-01	K-25
1780mm	1,2 [m]	1,2 [m]
2275mm	1,1 [m]	1,1 [m]

4. The First, remove the tiles at the bracket locations. Removing the tiles will allow access to the rafters. Then you need to sand the tile locks so that the installed hook does not rest on the tiles. Place the mounting bracket against the rafters and attach it with a minimum of two K-16 screws of the appropriate length (no pre-drilling).

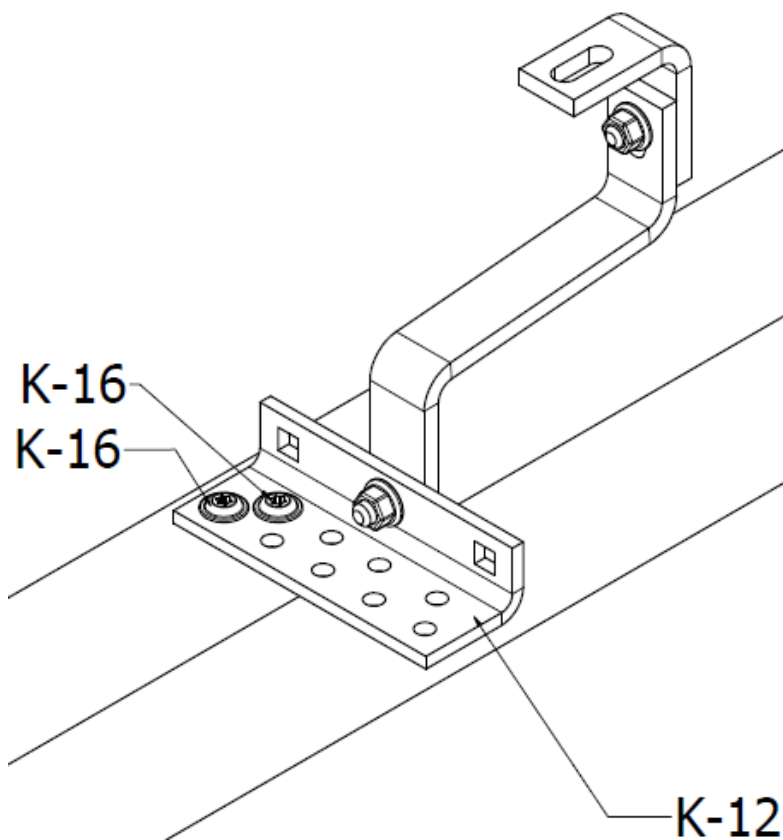

FIGURE. 6 Mounting of the bracket to the rafters

5. After mounting the brackets, prepare the mounting profiles by connecting them to the appropriate length using the K-02 connectors placed at the ends of two adjacent profiles. Bolt the connector together using two K-19 "T" bolts. Profiles can be cut to the required length.  
**ATTENTION: The minimum useful length of the profile in the construction is 500mm.**

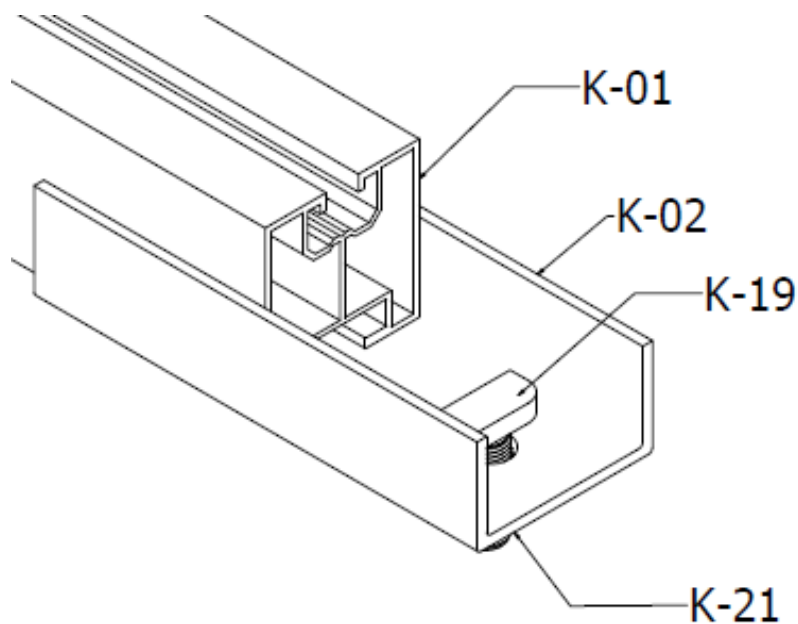

FIGURE. 7 Mounting of the K-02 connector with the K-01 profile

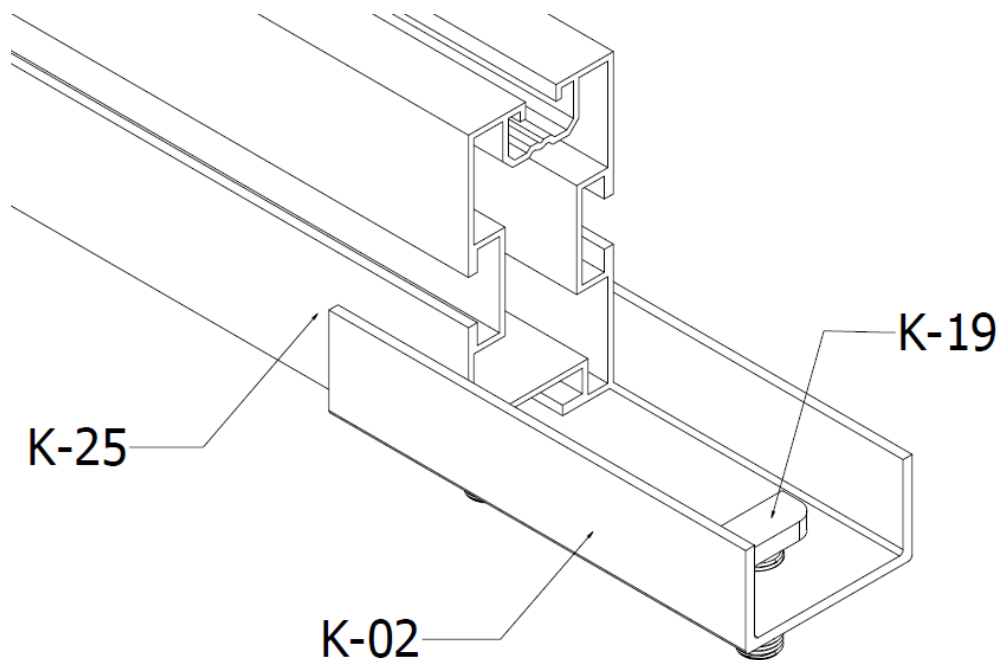

FIGURE. 8 Mounting of the K-02 connector with the K-25 profile

6. The prepared profiles should be attached to the installed hooks using "T" bolts. The heads of the bolts must go into a specially designed channel through the bean type holes in the mounting bracket.

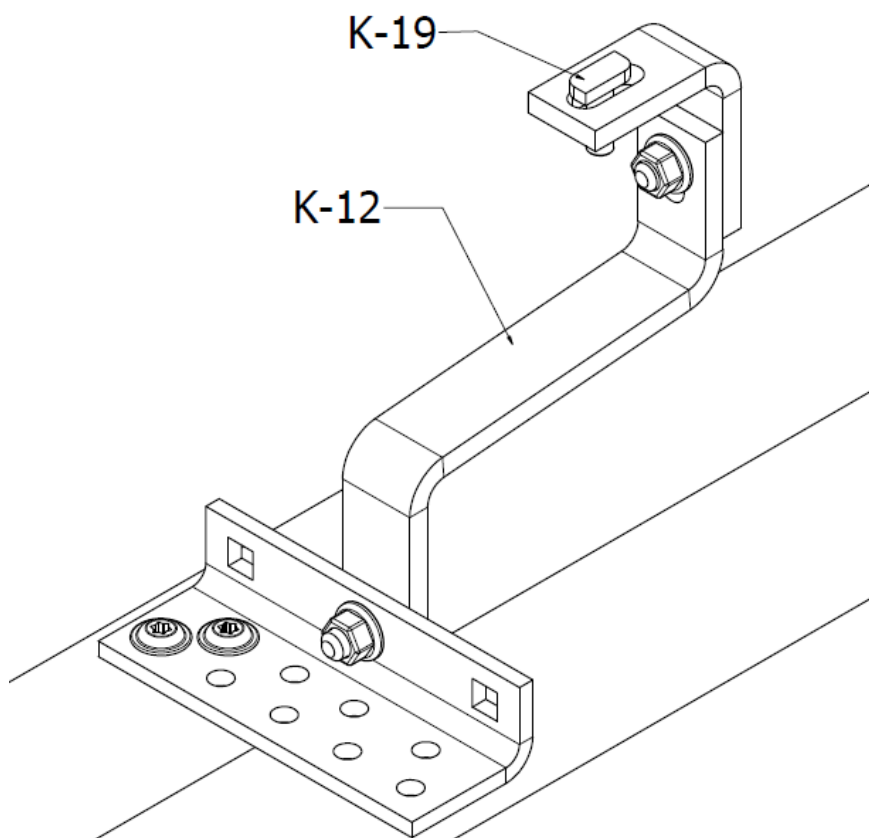

FIGURE. 9 Mounting of "T" bolts

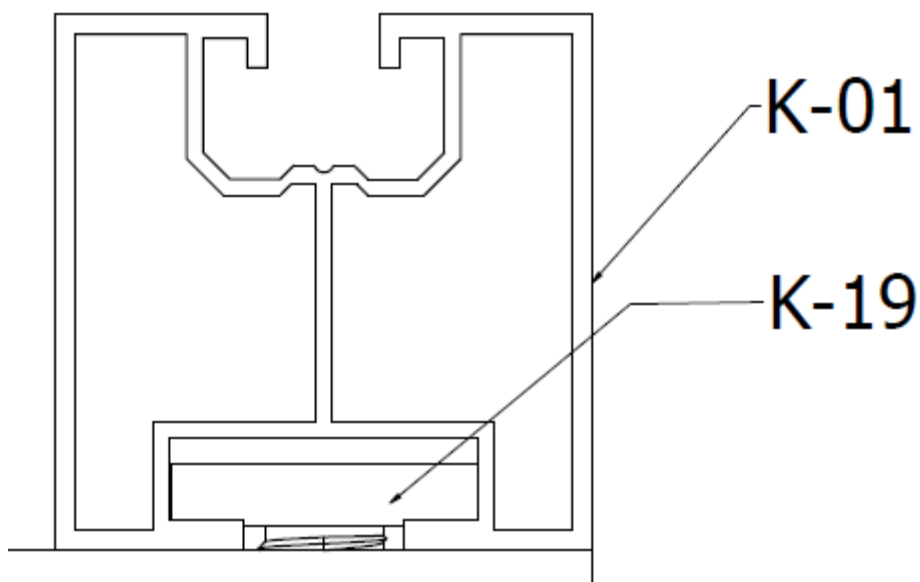

FIGURE. 10 Mounting of profile K-01



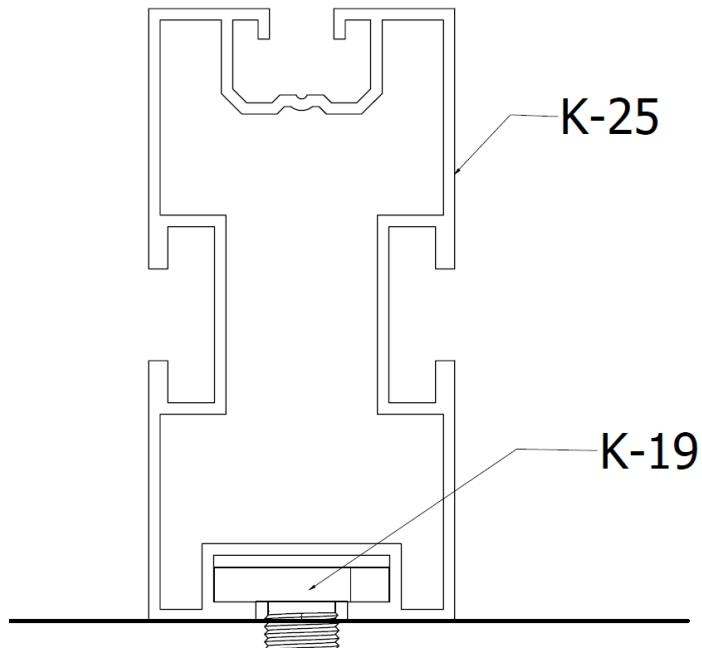

FIGURE. 11 Mounting of profile K-25

7. Thread the K-21 nuts onto the protruding threads from the K-19 bolts.

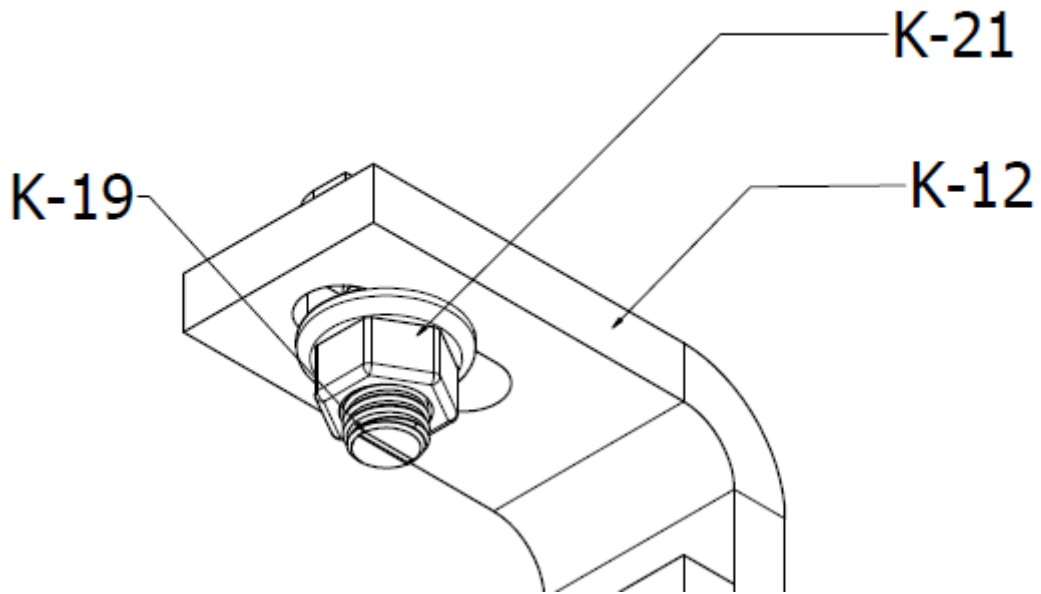

FIGURE. 12 Mounting of "T" bolts

8. The prepared structure should be bolted together with a torque of 30Nm
9. The K-04 t-slot nut can be mounted to the so prepared structure in a specially prepared channel. It can be mounted in any desired location

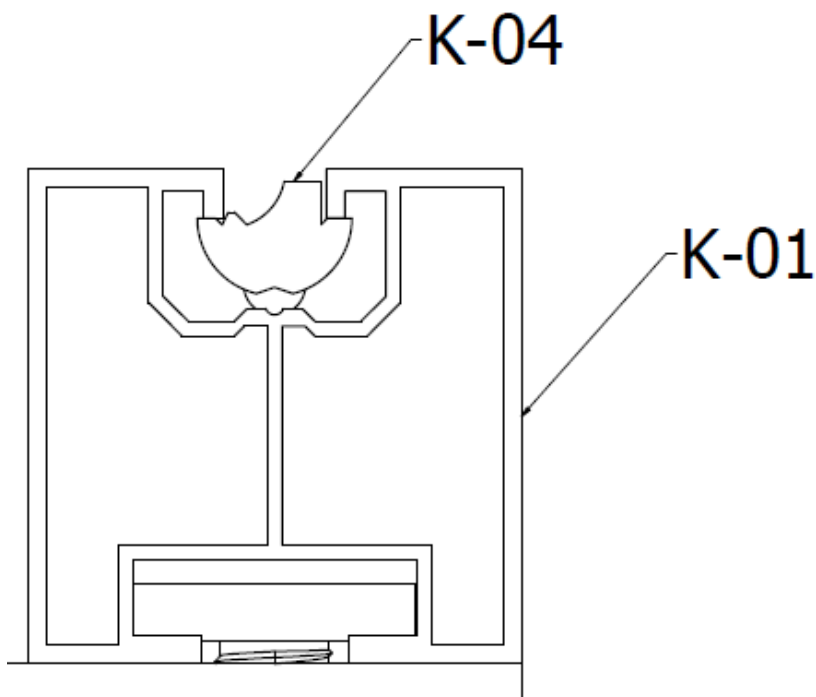

FIGURE. 13 Mounting of the K-04 nut to K-01 profiles

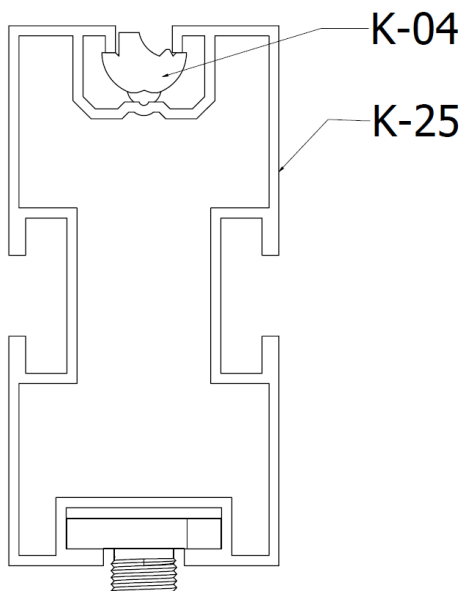

FIGURE. 14 Mounting of the K-04 nut to K-01 profiles

**10.** Then insert the K-06 end clamps into the first beam with the K-18 allen bolts. The first from the edge and the last from the edge will always be the end clamp, stabilizing the edge of the first and last module in a row. The mid clamps, on the other hand, will simultaneously stabilize the sides of the two modules. Properly selected edge clamps will have a height equal to the module thickness, the allen bolts will be 10mm shorter than the module thickness, and the mid clamps are universal and fit any module thickness

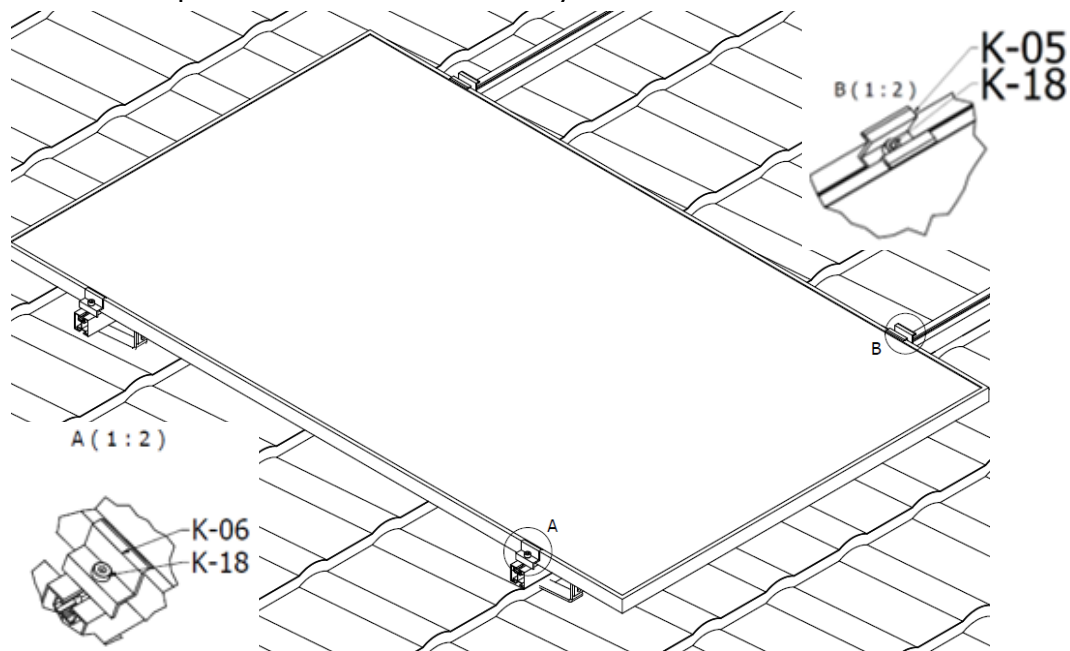

FIGURE. 15 Mounting of the modules and mounting the K-05 and K-06 clamps

**11.** Tighten clamps to a torque of 18Nm.

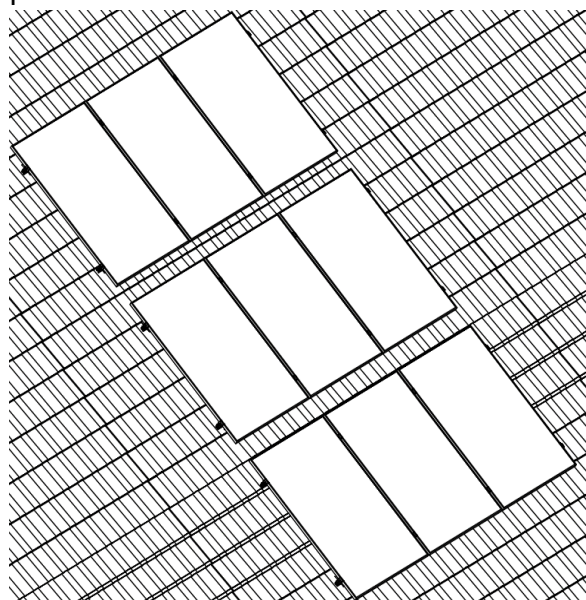

FIGURE. 16 View of assembled structure with modules

**Thank you for using KENO Sp z o.o. construction**

v. 09.01.2023